

BOLT DETAILS.

1/ -FOR ALUMINIUM PARAPETS:-

M20 HEX. HEAD STAINLESS STEEL SETPIN TO BS.EN.ISO.3506-1: 1998 GRADE A4-80. M20x37 o/dia. STAINLESS STEEL WASHERS SHALL BE MADE FROM S.S. STRIP GRADE 316S31 COMPLYING WITH BS 1449: PART 2 AND SHALL COMPLY WITH BS 4320 FORM 'B'.

POLYPROPYLENE HMT TOP HAT SPACER TO BE PLACED BETWEEN UNDERSIDE OF WASHER AND BASEFLATE OR OTHER EQUAL APPROVED.

2/ -FOR GALVANISED STEEL PARAPETS:-

M20 HEX. HEAD STAINLESS STEEL SETPIN TO BS.EN.ISO.3506-1: 1998 GRADE A4-80. 50 o/dia.x44mm THICK STEEL WASHERS HOT DIPPED GALVANISED.

POLYPROPYLENE HMT TOP HAT SPACER TO BE PLACED BETWEEN UNDERSIDE OF BOLT HEAD AND WASHER OR OTHER EQUAL APPROVED.

BOLT ENGAGEMENT:-

LENGTH OF TOP BOLT TO BE DETERMINED BY PARAPET INSTALLER TO SUIT SITE CONDITIONS TO ENSURE A MINIMUM THREAD ENGAGEMENT OF 25mm. STANDARD ANCHORAGES ARE SUPPLIED WITH TEMPORARY BOLTS. LENGTH OF PERMANENT HOLDING DOWN BOLTS TO SUIT SITE CONDITIONS.

PROTECTION:-

THREADS OF ANCHORAGE SOCKETS TO BE COATED WITH GREASE, HAVING A HIGH RESISTANCE TO CREEP, DURING MANUFACTURE. A FURTHER COAT, IF NECESSARY, TO BE APPLIED DURING FINAL ERECTION ON SITE.

FINISHES:-

THE ANCHORAGE IS SELF COLOUR.

WELDING:-

ALL WELDS ARE TO BE ACCORDANCE WITH BS 7475.

METHODS OF DESPATCH:-

THE ANCHORAGES ARE SENT TO SITE WITH PLYWOOD BOLTED TO SOCKETS. THE PLYWOOD ENSURES THAT THE CROSS CENTRES OF THE SOCKETS ARE MAINTAINED DURING POURING.

FIXING:-

THE PLYWOOD IS TO BE NAILED TO THE SHUTTERING BEFORE POURING. IF IT IS NECESSARY TO REMOVE THE PLYWOOD THIS SHOULD NOT BE DONE UNTIL THE CONCRETE IS SET SUFFICIENTLY TO PREVENT ANY DISTURBANCE OF THE ANCHORAGE, AND THE BOLTS MUST BE REPLACED IN THE SOCKETS. TO ENSURE THAT THEY ARE NOT LOST, AND THE SOCKET THREADS ARE KEPT CLEAN. POST ERECTION:-

AFTER REMOVING THE BOLTS FROM THE SOCKET, THE POST IS FIXED WITH NOMINAL PACKING OF INERT MATERIAL, PLACED OFF-CENTRE OF THE POST TO ACHIEVE THE GROUT PAD THICKNESS. IN PRACTICE TO ACHIEVE A SATISFACTORY LINE AND LEVEL TO THE RAILINGS, THIS HAS TO BE INCREASED OR REDUCED. THE BOLTS ARE TIGHTENED DOWN AGAINST THE PACKERS AND THE GROUT PAD IS FORMED, AFTER THE LINE AND LEVEL HAVE BEEN APPROVED BY THE RESIDENT ENGINEER.

THE DESIGN AND MANUFACTURE OF THE VARLEY AND GULLIVER ANCHORAGE COMPLIES WITH THE SPECIFICATION FOR HIGHWAY WORKS VOLUME 1 OF THE MANUAL OF CONTRACT DOCUMENTS FOR HIGHWAY WORKS AND BS 6779: PART 1: 1998.

THIS DESIGN OF ANCHORAGE IS FOR MANUFACTURE BY V & G ONLY AND SPECIFIERS SHOULD ENSURE THAT COPIES MADE BY UN-AUTHORISED MANUFACTURERS, WHO MAY NOT HAVE SATISFIED THE BBA APPROVAL REQUIREMENTS, ARE NOT ACCEPTED.



VARLEY AND GULLIVER LTD.

ALFRED STREET,
SPARKBROOK,
BIRMINGHAM B12 8UR
TEL. 0121-773-2441 FAX. 0121-766-6875

NOTE:-
TOPS OF ANCHORAGE SOCKETS TO BE SET LEVEL WITH HIGH POINT OF CONCRETE UPSTAND:
TOLERANCE + 0
- 5mm

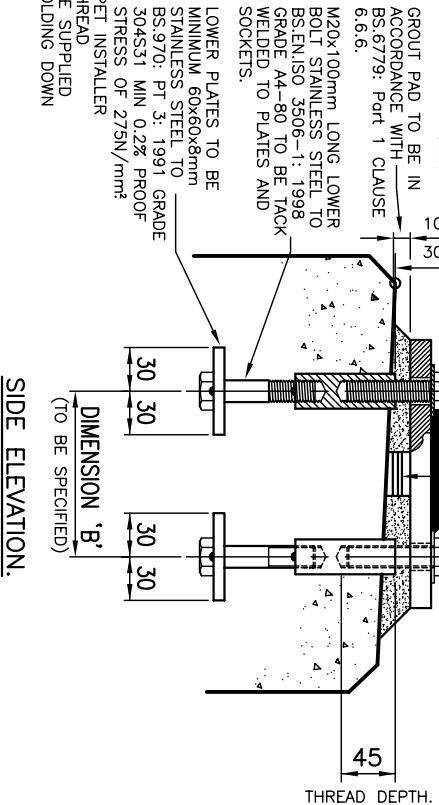

THE CONCRETE PLINTH IS TO BE DESIGNED TO RESIST WITHOUT DAMAGE THE FORCES TRANSMITTED BY THE PARAPET CONTAINMENT LEVEL UNDER IMPACT.

30mm MINIMUM DIA. 316S31 OR 316S33 STAINLESS STEEL PLAIN BAR WITH MINIMUM 0.2% PROOF STRESS OF 550N/mm² AND MINIMUM JTS OF 650N/mm² CONFORMING TO BS. 970: PT 3: 1991. 100mm LONG, WITH ONE END DRILLED & TAPPED M20x45 min. DEEP AND THE OTHER END DEEP DRILLED & TAPPED M20x20 min. TO ENSURE A MINIMUM THREAD ENGAGEMENT OF 20mm.

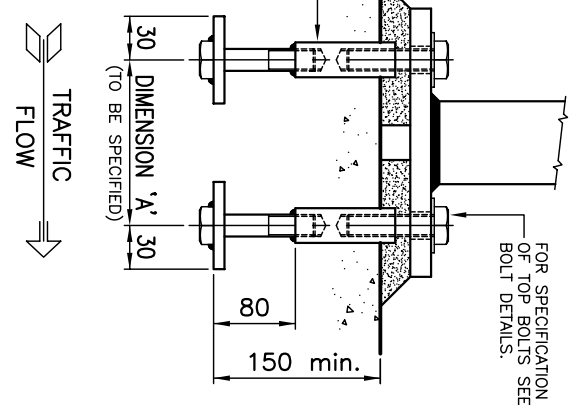

THIS ANCHORAGE MUST BE CAST WITH 3mm THICK STEEL PLATE AND PLYWOOD TEMPLATE IN POSITION TO ENSURE THAT CORRECT BOLT CENTRES ARE MAINTAINED.

ALL STAINLESS STEEL ANCHORAGE.
N.B. THIS DRAWING SUPERSEDES DRAWING NUMBER SM/11D.

THIS ANCHORAGE IS SUITABLE FOR ALL PARAPET DESIGNS LISTED IN BS 6779: PART 1: 1998, REQUIRING M20 BOLTS.
DIMENSION 'A' & DIMENSION 'B' TO SUIT SPECIFIC DESIGNS.

TOLERANCES

TITLE

ALL DIMENSIONS ARE ±1mm
NOTE: ACCUMULATIVE TOLERANCES ARE TO BE KEPT WITHIN THE OVERALL TOLERANCE.

V&G M20 ANCHORAGE TYPE 2.
ALL STAINLESS STEEL.

DRAWING NUMBER

VGAS/2.

18/10	OCTOBER 2000.	D.V.C	A.E.
DATE	ISSUED	DRAWN	CHECKED
REVISIONS			

THIS COMPANY RESERVE THE RIGHT TO MAKE ANY AMMENDMENTS CONSISTANT WITH APPROVAL WITHOUT PRIOR NOTICE.

THIS DRAWING TO BE USED ONLY WITH W/0.No.

DRAWING TO BE RETURNED TO DRAWING OFFICE ON COMPLETION OF WORK