



Varley and Gulliver Steel Parapets.

Marsh Road, Middlesbrough TS1 5JS
Tel. 44 (0) 1642 245151, Fax. 44 (0) 1642 254350

Website. www.v-and-g.co.uk

A Division of Varley & Gulliver Limited.

Fabricators in Aluminium and Steel to the Construction and Engineering Industries

STEEL VGSN 1000 SERIES VEHICLE RESTRAINT SYSTEM.

CONTENTS

SECTION A – SPECIFICATION MANUAL.

Letter of Endorsement from UKAS accredited test facility

1.0	List of Drawings:	5
1.1	System Drawings	5
2.0	List of Varley and Gulliver Limited Company Procedures for Production:	6
2.1	Table 1	6
3.0	Product Description	7
4.0	Durability	8
5.0	Compliance with EN.1317:	9
5.1	EN.1317-1: 1998 and EN.1317-2:1998	9
5.2	prEN.1317-5:	9
6.0	Recommendations for Use:	10
6.1	Minimum plinth dimensions	10
6.2	Working width restraints	10
6.3	Minimum length of parapet	10
6.4	Horizontal and Vertical alignment	10
7.0	Technical Information:	11
7.1	Post Capacity:	11
7.1.1	Ultimate Unfactored Design Moment of Resistance of Post.	11
7.1.2	Co-existent Shear.	11
7.1.3	Ultimate Shear Force Resistance of Post.	11
7.2	Anchorage Capacity:	11
7.2.1	Characteristic Load Values.	11
7.2.2	Serviceability Limit State Value.	11
7.2.3	Ultimate Limit State Value.	11
7.3	System Weights:	11
7.3.1	VGSN 1001	11
7.3.2	VGSN 1002	11
7.3.3	VGSN 1003	11
7.3.4	VGSN 1004	11
7.3.5	VGSN 1005	11
7.3.6	VGSN 1006	11
7.3.7	VGSN 1007	11
7.3.8	VGSN 1008	11
7.3.9	VGSN 1009	11
7.3.10	VGSN 1010	11

CONTENTS

8.0 Certification:	12
8.1 BS.EN.ISO 9001:2000 Quality Management Certificate	12
9.0 Design of Parapet system:	13

SECTION B – INSTALLATION MANUAL.

1.0 Scope:	15
1.1 Scope of Work	15
2.0 Safety:	16
2.1 Compliance	16
2.2 Management	16
2.3 Training	16
2.4 Personal Protective Equipment	16
2.5 Site	16
2.6 Access	16
2.7 Other operatives	16
3.0 Sequence of Operations:	17
3.1 Erection of Posts and Rails	17
3.2 Grouting under Baseplates	18
3.3 Fixings of Mesh Infill	19
4.0 Routine Inspection:	21
4.1 Guidance for Inspection	21
4.2 Accident Damage Inspection	21

SECTION 'A' – SPECIFICATION MANUAL.

1.0 List of Drawings.

1.1 System Drawings. (Attached.)

<u>DRAWING NUMBER</u>	<u>DRAWING TITLE.</u>
VGSN 1000-01:	STANDARD ARRANGEMENT DRAWINGS OF VGSN 1000 SERIES STEEL PARAPET SYSTEM. VGSN 1001 AND VGSN 1002.
VGSN 1000-02:	STANDARD ARRANGEMENT DRAWINGS OF VGSN 1000 SERIES STEEL PARAPET SYSTEM. VGSN 1003 AND VGSN 1004.
VGSN 1000-03:	STANDARD ARRANGEMENT DRAWINGS OF VGSN 1000 SERIES STEEL PARAPET SYSTEM. VGSN 1005 AND VGSN 1006.
VGSN 1000-04:	STANDARD ARRANGEMENT DRAWINGS OF VGSN 1000 SERIES STEEL PARAPET SYSTEM. VGSN 1007 AND VGSN 1008.
VGSN 1000-05:	STANDARD ARRANGEMENT DRAWINGS OF VGSN 1000 SERIES STEEL PARAPET SYSTEM. VGSN 1009 AND VGSN 1010.
VGSN 1000-06:	STANDARD ARRANGEMENT DRAWINGS OF VGSN 1000 SERIES STEEL PARAPET SYSTEM. RAIL CONNECTION DETAILS. (90x90 RAILS.)
VGSN 1000-07:	STANDARD ARRANGEMENT DRAWINGS OF VGSN 1000 SERIES STEEL PARAPET SYSTEM. RAIL CONNECTION DETAILS. (120x80 RAILS.)
VGSN 1000-08:	STANDARD ARRANGEMENT DRAWINGS OF VGSN 1000 SERIES STEEL PARAPET SYSTEM. PARAPET POST DETAILS.
VGSN 1000-09:	STANDARD ARRANGEMENT DRAWINGS OF VGSN 1000 SERIES STEEL PARAPET SYSTEM. PARAPET MESHING DETAILS. (OPTION 1.)
VGSN 1000-10:	STANDARD ARRANGEMENT DRAWINGS OF VGSN 1000 SERIES STEEL PARAPET SYSTEM. PARAPET MESHING DETAILS. (OPTION 2.)
VGSN 1000-11:	STANDARD ARRANGEMENT DRAWINGS OF VGSN 1000 SERIES STEEL PARAPET SYSTEM. VGSN 1010 SHEETING AND MESHING DETAILS.
VGSN 1000-12:	STANDARD ARRANGEMENT DRAWINGS OF VGSN 1000 SERIES STEEL PARAPET SYSTEM. SOLID INFILL SHEETING DETAILS.
VGSN 1000-13:	STANDARD ARRANGEMENT DRAWINGS OF VGSN 1000 SERIES STEEL PARAPET SYSTEM. ANTI-ACCESS PANELLING DETAILS.
VGSN 1000-14:	STANDARD ARRANGEMENT DRAWINGS OF VGSN 1000 SERIES STEEL PARAPET SYSTEM. SAFETY FENCE CONNECTOR DETAILS.

2.0 List of Varley and Gulliver Limited Company Procedures for Production.

All procedure references relate to Varley and Gulliver Limited Quality Assurance manual in accordance with **ISO 9001:2000** approved procedures.

Name of procedure:	Procedure Reference Number:
Product Realisation (Inspection of Raw Materials):	7.1
Inspection of Components and Fasteners:	7.1
Routine inspections carried out during manufacture:	7.1
Handling and Storage of Materials:	7.1
Control of measuring equipment:	4.2.4 and 7.1
Assessment of Personnel:	6.2
Control of Specification Manual:	4.2.4
Control on incoming Materials:	7.1 and 7.4.2
Traceability of Materials:	7.1
Corrective and preventive actions to be taken:	8.5.2 and 8.5.3
Continuous surveillance via Internal Audits:	8.2.2
Appointment and control of suppliers and subcontractors:	7.4.1

Table 1.

3.0 Product Description:

The VGSN 1000 series Steel parapet is a **modular system** providing supporting posts are spaced at **3.660m centres**. Exceptions are at Type 3 expansion joint locations where posts spanning the joint should not exceed 1.5m. Closer post centres may be used for single bays where this cannot be avoided at movement joints and end bays of parapet runs.

The system consists of 3, 4 or 5 horizontal rail sections varying in size between either 90mm x 90mm or 120mm x 80mm located to supporting posts at heights specified on system drawings. The rails are nominally 7.320m long with ends punched with 20mm diameter holes to receive bolted rail to rail connection joints. Shorter rail lengths are utilised at expansion joints and ends of runs.

Rails are joined together with internal rail joint sleeves 80mm x 80mm x 5mm and 108mm x 68mm x 6mm thick, which are slotted in the top and bottom faces to accept 3No. M16x120mm long (90 x 90 rail.) and M16x110mm long (120 x 80 rail.) galvanised steel bolts which pass through the rail and joint and are secured with M16 galvanised nuts.

There are three types of rail joint to accommodate varying degrees of expansion or contraction.

Type 1 joint (Standard) accommodates movement range upto +/- 5mm.

Type 2 joint (Expansion) accommodates movement range upto +/- 25mm.

Type 3 joint (No-Tension Expansion) accommodates movement range upto +/- 150mm.

The rails are attached to the supporting posts via specially fabricated post to rail cleats Type 1 and 2. Rails are attached to cleats with 2no. M16x130mm long (90 x 90 rail.) and M16x120mm long (120 x 80 rail.) galvanised steel bolts fitted vertically to clamp the cleats and rail together, bolts are secured with M16 galvanised nuts.

Rail cleats Type 1 and 2 are attached to posts with M16x35mm long galvanised setpins fastened into thermally drilled and tapped holes in the post.

The supporting posts are fabricated from 270x270x25mm thick steel baseplates with 120x120x5mm thick steel RHS posts welded centrally with 12mm fillet weld all round.

Posts are usually attached to the bridge structure or retaining wall with 4No. M20 stainless steel holding down bolts into **HAPAS** approved cast-in anchorage units or resin fixed drilled anchorages. The holding down bolts are isolated from the galvanised washers and baseplate with a nylon top hat washer.

4.0 Durability:

The durability of a product is dependent upon numerous factors such as weather conditions, air pollution, location, handling, repair and routine maintenance. In the case of steel product protected by Hot dip galvanising durability is also dependent upon the thickness of the protective coating.

The main rails, posts, cleats and joints are Hot Dipped Galvanised in accordance with BS.EN.ISO.1461:1999.

After galvanising an extremely thin protective film of zinc oxide forms on the surface which is impervious and tightly adherent to the zinc. With time the zinc oxide thickness increases and the original bright shiny surface of the zinc changes to a dull light grey colour.

The use of stainless steel fixings in contact with galvanised surfaces can raise concern of bi-metallic corrosion (Galvanic corrosion).

The main area of concern would be the holding down bolts and the baseplate which would be prone to standing water and road salts and for this reason a nylon top hat isolation washer is utilised between the stainless holding down bolt and the galvanised washer.

Splashes of alkaline building materials like grout and concrete, cement cause visible spots on the surface of the galvanising caused by slight etching when drying or setting. The etching will stop once dry or set.

Accumulation of dirt and debris on surfaces can cause a reduced durability due to the consequence of long-term moisture. Dirt and debris should be removed during routine inspections.

The most important contaminant for zinc is sulphur dioxide and its presence largely controls the atmospheric corrosion of zinc. Specific corrosion values in the UK have been mapped by the Agricultural Development Advisory Service. The Zinc Millennium map is available on the Galvanisers Association website (www.hdg.org.uk). The map gives the corrosion rate of galvanising in 10km areas throughout the UK. As the rate of corrosion for zinc is generally linear for a given environment the map can be utilised to establish the life expectancy of a galvanised product.

The average thickness of the galvanised product divided by the corrosion rate for a specified location will determine the expected minimum life of the galvanised coating in years.

Therefore to specify an exact working life duration is virtually impossible but would predict a durability of the product with an average thickness of coating of 85 microns in an industrial environment to be over 25 years dependent upon routine inspection, repair and maintenance.

A supplementary paint system may be applied for aesthetics.

5.0 Compliance with EN.1317.

5.1 EN.1317-1: 1998 and EN.1317-2:1998.

The **VGSN 1000** series Steel vehicle restraint system as shown on drawing **VGSN 1000-01** has been crash tested and certified reports prepared in compliance with **EN.1317-1: 1998** and **EN.1317-2: 1998**.

MIRA Limited undertook a **TB11** crash test on **11 August 2005** and subsequently prepared report number **MIRA-05-1010208** which certifies the Containment Level as **N2** with a working width class of **W1**.

MIRA Limited undertook a **TB32** crash test on **12 August 2005** and subsequently prepared report number **MIRA-05-1010209** which certifies the Containment Level as **N2** with a working width class of **W1**.

Severity Class level = **B**.

5.2 prEN 1317-5:2004

prEN 1317-5:2004 is currently in Draft format and is therefore not part of the EN.1317 product acceptance criteria.

Notwithstanding the above the proposed standard does not incorporate additional requirements over and above the current ISO 9001:2000 quality management system.

For the purposes of product acceptance during the interim period The Highways Agency (UK) are acting as a quasi notified body.

6.0 Recommendations for Use.

This vehicle restraint system is suitable for use on highways where the following provisions can be met:-

6.1 Minimum plinth dimensions.

The minimum width of the bridge or retaining wall stringcourse (plinth) shall be **450mm** wide.

The upstand at the traffic face adjacent to the paved surface shall be a minimum of 50mm and the maximum cross sectional profile of the plinth shall not exceed 100mm.

6.2 Working Width restraints.

The distance from the traffic face of the restraint system to any obstruction behind the restraint system (lighting column, sign post etc.) shall be a minimum of **0.6m**.

6.3 Minimum Length of parapet.

The minimum recommended length for the product installation is **14m**.

6.4 Horizontal and Vertical Alignment.

The minimum horizontal curvature without pre-curving of main rails is 75m.

Smaller radii can be accommodated by special arrangement with pre-curving.

Post cleats can accommodate vertical alignments of upto +/-6°.

Posts are usually welded perpendicular to baseplates.

However, when the vertical alignment results in a longitudinal fall in excess of 5° the baseplates should be raked to follow the alignment while the posts remain vertical.

7.0 Technical Information.

7.1 Post Capacity:

- 7.1.1** Ultimate Unfactored Design Moment of Resistance of Post.
The ultimate unfactored design moment of resistance of the posts at the underside of the post baseplate = **26.235 kNm.**
- 7.1.2** Co-existent Shear.
The co-existent shear = **50.13 kN.**
- 7.1.3** Ultimate Shear Force Resistance of post.
The ultimate shear for resistance of the post = **174.65 kN.**

7.2 Anchorage Capacity:

- 7.2.1** Characteristic Load Value.
The characteristic value of actions due to loads = **63.99 kN.**
- 7.2.2** Serviceability Limit State Value.
The serviceability limit state value = **70.39 kN.**
- 7.2.3** Ultimate Limit State Value.
The ultimate limit state value = **115.19 kN.**

7.3 System Weights:

Weights are based on 3.660m centres, anchorage units type VGAS/1 and meshing as Option 1.

- 7.3.1 VGSN 1001** (1.00m high without mesh.)
Weight per metre = **51.90 kg/m.**
- 7.3.2 VGSN 1002** (1.00m high with mesh.)
Weight per metre = **55.48 kg/m.**
- 7.3.3 VGSN 1003** (1.25m high without mesh.)
Weight per metre = **65.04 kg/m.**
- 7.3.4 VGSN 1004** (1.25m high with mesh.)
Weight per metre = **68.92 kg/m.**
- 7.3.5 VGSN 1005** (1.40m high without mesh.)
Weight per metre = **66.12 kg/m.**
- 7.3.6 VGSN 1006** (1.40m high with mesh.)
Weight per metre = **70.14 kg/m.**
- 7.3.7 VGSN 1007** (1.50m high without mesh.)
Weight per metre = **66.63 kg/m.**
- 7.3.8 VGSN 1008** (1.50m high with mesh.)
Weight per metre = **70.72 kg/m.**
- 7.3.9 VGSN 1009** (1.80m high without mesh.)
Weight per metre = **80.34 kg/m.**
- 7.3.10 VGSN 1010** (1.80m high with part height solid and part height mesh infill.)
Weight per metre = **101.46 kg/m.**

The stated values could vary due to material, fabrication and installation tolerances, however, these values should be utilised for any design purposes.

8.0 Certification.

8.1 BS.EN.ISO 9001:2000 Quality Management Certificate.

9.0 Design of Parapet System.

The parapet system has been designed following the general principles defined in the following standards:

- **BS.EN.1011-1:1998** – Recommendations for welding of metallic materials. General guidance for arc welding.
- **BS.EN.1011-2:2001** – Recommendations for welding of metallic materials. Arc welding of ferretic steels.
- **BS.EN.287-1:2004** – Qualification test of welders. Fusion welding. Steels.
- **BS.EN.ISO.15607:2003** – Specification and qualification of welding procedures for metallic materials.
- **BS.EN.1317-1:1998** – Road restraint systems. Terminology and general criteria for test methods.
- **BS.EN.1317-2:1998** – Road restraint systems. Performance classes, impact test acceptance criteria and test methods for safety barriers.
- **BS.6779-1:1998** – Highway parapets for bridges and other structures. Specification for vehicle containment parapets of metal construction.
- **BS.5400-3:2000** – Steel, concrete and composite bridges. Code of practise for design of steel bridges.
- **BS.EN.ISO.1461:1999** – Hot dip galvanized coatings on fabricated iron and steel articles. Specification and test methods.

SECTION 'B' – INSTALLATION MANUAL.

1. Scope:

1.1 This Method Statement encompasses the work involved to erect **VGSAN 1000 Series** Steel Vehicle / Pedestrian parapet.

2.0 Safety:

2.1 All work will comply with the following:

2.1.1 The Health and Safety at Work Act.

2.1.2 Varley and Gulliver's Safety Handbook.

2.1.3 Varley and Gulliver associated Method Statement(s) & Risk Assessment(s).

2.1.4 Any Site Inductions given by the Main Contractor.

2.2 All Varley & Gulliver Limited Site operatives will be experienced tradesmen. The nominated Contract Manager and Installation Supervisor will ensure safe working practices are adhered to by Varley & Gulliver Limited employees during the duration of on site work. Any other matters are to be directed to Varley & Gulliver Limited Contracts Division.

2.3 All operatives will comply with Site Safety Procedures as specified by Varley & Gulliver & the Main Contractor. All Plant operators will be trained and certified in the safe operation and use of the equipment they are utilising.

2.4 All personnel will wear the correct PPE for the task in hand. High Visibility clothing, Safety Footwear and Hard Hats will be worn as a matter of course.

2.5 The contents of the Method Statement and associated Risk Assessments shall be communicated to ALL erection teams prior to commencement of work.

2.6 Clear vehicular access must be provided for our lorries to load/unload and for our vans whilst work is ongoing.

2.7 No other trades to have access to work areas whilst Varley & Gulliver's operations are ongoing.

3.0 Sequence of Operations:

3.1 Installation of Posts and Rails:

- 3.1.1** No work will commence until items 2.6 & 2.7 have been met.
- 3.1.2** Check that anchorage sockets are clean and free of debris. Clean out as necessary.
- 3.1.3** Lay out in front of each post location the M20 stainless steel holding down bolts c/w M20 x 50 o/dia x 4mm thick galvanised steel washers and plastic top hats as required. Place washers onto holding down bolts to ensure that the plastic top hat washer is in contact with the underside of the bolt head upon installation.
- 3.1.4** Identify positions from the General Arrangement (GA) drawings and place all posts and rails in the required locations. Locate post over anchor cluster and insert the M20 bolts with washers through the baseplate into the anchorage sockets. Ensure that the threads of all bolts have a thin coat of grease applied (copper slip or similar) prior to fitting.
- 3.1.5** Lean post and place 20mm solid inert packer(s) as close to the centre hole of the baseplate as possible. Ensure that the threads of all bolts have a thin coat of grease applied (copper slip or similar) prior to fitting.
- 3.1.6** Plumb posts in both elevations using the central packer, and by rocking front to side. Do not tighten the M20 bolts at this stage, bolts should be no more than finger tight.
- 3.1.7** Repeat items **3.1.3** – **3.1.6** along length of work area.
- 3.1.8** Fix the post to rail cleats to posts using M16x35 long galvanised steel set pins c/w M16 galvanised spring washer and M16 plain washer. Note the specific locations for each type of cleat. Fixings to be finger tight only at this stage. Alternatively cleats can be fixed to the posts in the factory prior to despatch.
- 3.1.9** Starting at one end of the structure begin erecting the rails by laying them on battens/packers, to avoid damage, on the structure. Offer the rails up into position (starting with the bottom rail) and fit the cleat/rail fixings. M16x120 galvanised steel bolts for the bottom two rails and M16x130 galvanised steel bolts for the remaining rails.
- 3.1.10** Once the first set of rails are installed, plumb the end of the rails and tighten post/rail bolts. Do not fully tighten at this stage.
- 3.1.11** Determine from the GA layout drawing if safety fence connectors are to be installed at the ends of the rails and proceed to fit (if required).

3.1.12 For the 90x90 rails insert the 80x80 rail to rail joints pieces and fix with M160x120 long galvanised steel bolts, M16 galvanised nuts and washers. For the 120x80 rails insert the 108x68 rail to rail joints pieces and fix with M16x110 long galvanised steel bolts, M16 galvanised nuts and washers.

3.1.13 Repeat steps **3.1.9** and step **3.1.12** along entire length of the work area, ensuring the correct rail joints are fitted and the correct gaps are set (see GA drawing).

3.1.14 Repeat step **3.1.1** at the other end (if required).

3.1.15 Line and level by means of eying in the top rail, lifting and lowering posts using thin shims for level and using rocking action for alignment.

3.1.16 Check and tighten **ALL** bolts.

3.1.17 When parapets are attached to Varley and Gulliver Limited anchorage units the length of bolt engagement needs to be a minimum of 25mm. When parapets are attached to anchorage provided by other the following equation should be followed:

$$LE = 0.7 \times \frac{\text{Ultimate Tensile Strength of Fixings}}{0.2\% \text{ Proof Stress of Anchorage Socket}} \times D$$

Where:

LE = Length of Engagement

D = Bolt Diameter.

3.1.18 Line and Level to be passed off and Job Instruction Sheets to be completed and passed to the relevant representative from the client for approval and signature.

3.2 Grouting under Baseplates:

3.2.1 If the temperature is likely to fall below 5 degrees Centigrade for 24 hours either side of pouring the grout either:

a) Cover area with hessian, providing temperature is not likely to fall to freezing point.

b) DO NOT grout.

3.2.2 Using 2" x 1" wood, construct a grouting frame slightly bigger than the baseplate. (See Figure 1.)

3.2.3 Nail the frame together and apply silicone sealant (where appropriate) to the outside of the frame when positioning, to stop any grout from seeping out.

3.2.4 Place the frame around the baseplate and pour in an approved non-shrink grout at the high end (See Figure 2.) Ensure that the grout runs through to all sides.

3.2.5 Leave the grout to set. (as per manufacturers' recommendations).

3.2.6 Once set remove the frame.

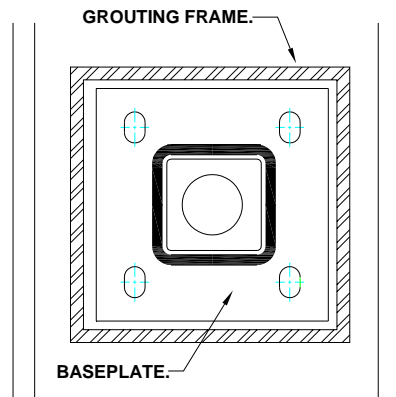

Figure 1.

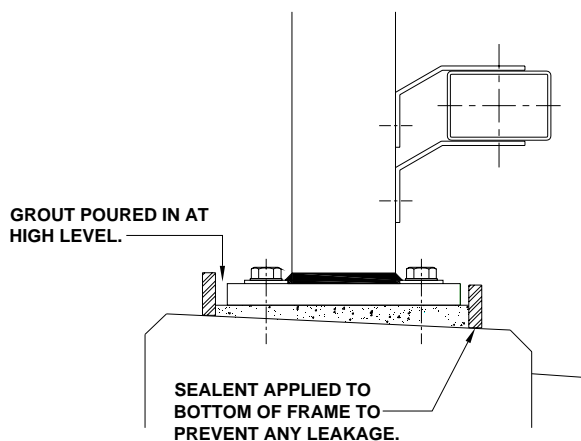

Figure 2.

3.2.7 When grout boxes are removed the holding down bolts are to be re-tightened.

3.2.8 Job Instruction Sheets to be completed and passed to relevant representative from the client for approval and signature.

3.3 Mesh Infilling:

3.3.1 Starting from one end (preferably the left corner) proceed to layout the bottom mesh rail along entire length of work area. (If required.)

3.3.2 Using associated bolts, nuts and washers identified from GA layout drawing proceed to fix bottom mesh rail along length of work area.

3.3.3 Starting from one end (preferably the left corner) proceed to layout the mesh panels along length of work area, along with top flashing (if required) and mesh retaining clips.

3.3.4 Secure mesh panels to front face of rails by means of drilling a 4.9mm hole, mesh retaining clip and drive rivet (extra short). Cut panels at expansion joints and fit plastic caps.

3.3.5 Proceed along entire length of work area repeating step **3.3.4**.

3.3.6 Fix vertical end flashings at ends of runs and at expansion joint locations. Proceed to fix top flashing (if required) to top rail along entire run, drilling 4.9mm holes at centres not exceeding 203mm, fixed with drive rivets (extra long). Top flashing to stop / start at all rail joint locations.

3.3.7 After steps **3.3.2 – 3.3.6** remove all swarf from rails and posts using a soft hand brush. Collect up all off cuts and dispose of off site.

Job Instruction Sheets to be completed and passed to relevant representative from the client for approval and signature.

4.0 Routine Inspections:

4.1 It is recommended that a general inspection of the steel parapet is carried out during routine and principle inspections of the main structure.

4.2 Guidance for Inspection:

The following items should be reviewed as part of the inspection:

- Absence or looseness of bolts or nuts.
- Absence of or damage to grout pad.
- Build up of debris and dirt.
- Adequate attachment of mesh infill. (where applicable.)

4.3 Accident Damage Inspection:

The following items should be reviewed as part of the inspection:

- Any cracks in or adjacent to welds. Particular attention to be paid to the post to baseplate weld.
- Damage to attachment cleats.
- Absence or looseness of bolts or nuts.
- Absence of or damage to grout pad.
- Build up of debris and dirt.
- Adequate attachment of mesh infill. (where applicable.)

If in any doubt contact Varley and Gulliver Limited who can offer advice or arrange a site visit.